

SECTION **SR**
SRS AIRBAG

A
B
C
D
E
F
G
SR
I
J
K
L
M
N
O
P

CONTENTS

PRECAUTION	2	Removal and Installation	21
PRECAUTIONS	2	SIDE AIR BAG MODULE	23
Precaution for Supplemental Restraint System (SRS) "AIR BAG" and "SEAT BELT PRE-TENSIONER"	2	Removal and Installation	23
Service	2	CRASH ZONE SENSOR	24
Precaution for Work	2	Exploded View	24
PREPARATION	4	Removal and Installation	24
PREPARATION	4	SATELLITE SENSOR	26
Special Service Tools	4	Exploded View	26
BASIC INSPECTION	5	Removal and Installation - Front Door Satellite Sensor	26
COLLISION DIAGNOSIS	5	Removal and Installation - Front Side Air Bag Satellite Sensor	27
For Frontal Collision	5	Removal and Installation - Rear Side Air Bag Satellite Sensor	28
For Side and Rollover Collision	7	AIR BAG DIAGNOSIS SENSOR UNIT	30
REMOVAL AND INSTALLATION	12	Exploded View	30
DRIVER AIR BAG MODULE	12	Removal and Installation	30
Exploded View	12	OCCUPANT CLASSIFICATION SYSTEM CONTROL UNIT	32
Removal and Installation	12	Removal and Installation	32
SPIRAL CABLE	16	SEAT BELT PRE-TENSIONER	34
Exploded View	16	Removal and Installation	34
Removal and Installation	16	FRONT SEAT BELT BUCKLE SWITCH	35
FRONT PASSENGER AIR BAG MODULE	19	Removal and Installation	35
Exploded View	19	FRONT PASSENGER AIR BAG OFF INDICATOR	36
Removal and Installation	19	Removal and Installation	36
SIDE CURTAIN AIR BAG MODULE	21		
Exploded View	21		

PRECAUTIONS

< PRECAUTION >

PRECAUTION

PRECAUTIONS

Precaution for Supplemental Restraint System (SRS) "AIR BAG" and "SEAT BELT PRE-TENSIONER"

INFOID:000000012430560

The Supplemental Restraint System such as "AIR BAG" and "SEAT BELT PRE-TENSIONER", used along with a front seat belt, helps to reduce the risk or severity of injury to the driver and front passenger for certain types of collision. Information necessary to service the system safely is included in the SR and SB section of this Service Manual.

WARNING:

- To avoid rendering the SRS inoperative, which could increase the risk of personal injury or death in the event of a collision which would result in air bag inflation, all maintenance must be performed by an authorized NISSAN/INFINITI dealer.
- Improper maintenance, including incorrect removal and installation of the SRS, can lead to personal injury caused by unintentional activation of the system. For removal of Spiral Cable and Air Bag Module, see the SR section.
- Do not use electrical test equipment on any circuit related to the SRS unless instructed to in this Service Manual. SRS wiring harnesses can be identified by yellow and/or orange harnesses or harness connectors.

PRECAUTIONS WHEN USING POWER TOOLS (AIR OR ELECTRIC) AND HAMMERS

WARNING:

- When working near the Airbag Diagnosis Sensor Unit or other Airbag System sensors with the Ignition ON or engine running, DO NOT use air or electric power tools or strike near the sensor(s) with a hammer. Heavy vibration could activate the sensor(s) and deploy the air bag(s), possibly causing serious injury.
- When using air or electric power tools or hammers, always switch the Ignition OFF, disconnect the battery and wait at least three minutes before performing any service.

Service

INFOID:000000012430561

- Do not use electrical test equipment to check SRS circuits unless instructed to in this Service Manual.
- Before servicing the SRS, turn ignition switch OFF, disconnect both battery cables and wait at least three minutes.
For approximately three minutes after the cables are removed, it is still possible for the air bag and seat belt pre-tensioner to deploy. Therefore, do not work on any SRS connectors or wires until at least three minutes have passed.
- Diagnosis sensor unit must always be installed with their arrow marks "←" pointing towards the front of the vehicle for proper operation. Also check diagnosis sensor unit for cracks, deformities or rust before installation and replace as required.
- The spiral cable must be aligned with the neutral position since its rotations are limited. Do not turn steering wheel and column after removal of steering gear.
- Handle air bag module carefully. Always place driver and front passenger air bag modules with the pad side facing upward and seat mounted front side air bag module standing with the stud bolt side facing down.
- Conduct self-diagnosis to check entire SRS for proper function after replacing any components.
- After air bag inflates, the instrument panel assembly should be replaced if damaged.
- Always replace instrument panel pad following front passenger air bag deployment.

Precaution for Work

INFOID:000000012430562

- When removing or disassembling each component, be careful not to damage or deform it. If a component may be subject to interference, be sure to protect it with a shop cloth.
- When removing (disengaging) components with a screwdriver or similar tool, be sure to wrap the component with a shop cloth or vinyl tape to protect it.
- Protect the removed parts with a shop cloth and prevent them from being dropped.
- Replace a deformed or damaged clip.
- If a part is specified as a non-reusable part, always replace it with a new one.
- Be sure to tighten bolts and nuts securely to the specified torque.
- After installation is complete, be sure to check that each part works properly.

PRECAUTIONS

< PRECAUTION >

- Follow the steps below to clean components:
- Water soluble dirt:
 - Dip a soft cloth into lukewarm water, wring the water out of the cloth and wipe the dirty area.
 - Then rub with a soft, dry cloth.
- Oily dirt:
 - Dip a soft cloth into lukewarm water with mild detergent (concentration: within 2 to 3%) and wipe the dirty area.
 - Then dip a cloth into fresh water, wring the water out of the cloth and wipe the detergent off.
 - Then rub with a soft, dry cloth.
- Do not use organic solvent such as thinner, benzene, alcohol or gasoline.
- For genuine leather seats, use a genuine leather seat cleaner.

A

B

C

D

E

F

G

SR

I

J

K

L

M

N

O

P

PREPARATION

< PREPARATION >

PREPARATION

PREPARATION

Special Service Tools

INFOID:000000012430563

The actual shape of the tools may differ from those illustrated here.

Tool number (TechMate No.) Tool name	Description
— (J-46534) Trim Tool Set	Removing trim components

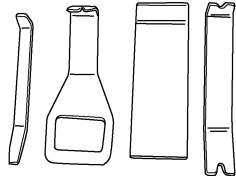

AWJIA0483ZZ

COLLISION DIAGNOSIS

< BASIC INSPECTION >

BASIC INSPECTION

COLLISION DIAGNOSIS

For Frontal Collision

INFOID:000000012430564

FOR FRONTAL COLLISION: When SRS is activated in a collision

CAUTION:

Due to varying models and option levels, not all parts listed in the chart below apply to all vehicles.

WORK PROCEDURE

1. Before performing any of the following steps, ensure that all vehicle body and structural repairs have been completed.
2. Replace the diagnosis sensor unit.
3. Remove the front air bag modules, crash zone sensor assembly, bracket and seat belt pre-tensioner assemblies.
4. Check the SRS components using the table below:
Replace any SRS components showing visible signs of damage. (dents, cracks and deformation, etc.)
5. Install new front air bag modules, crash zone sensor assembly, bracket and seat belt pre-tensioner assemblies.
6. Perform self-diagnosis using CONSULT or air bag warning lamp. Refer to [SRC-14, "Description"](#) for details.
Ensure entire SRS operates properly.
7. After the work is completed, perform self-diagnosis to check that no malfunction is detected. Refer to [SRC-14, "Description"](#).

SRS INSPECTION (FOR FRONTAL COLLISION)

Part	Inspection
Driver air bag module	If the driver air bag has deployed: REPLACE Install with new fasteners.
Front passenger air bag module (if equipped)	If the front passenger air bag has deployed: REPLACE Install with new fasteners.
Crash zone sensor	If any of the front air bags or seat belt pre-tensioners* have been activated: REPLACE the crash zone sensor and bracket with new fasteners. *: Confirm seat belt pre-tensioner activation using CONSULT only.
Seat belt pre-tensioner assemblies (All applicable locations: buckle, retractor, lap outer)	If either the driver or passenger seat belt pre-tensioner* has been activated: REPLACE all seat belt pre-tensioner assemblies with new fasteners. *: Confirm seat belt pre-tensioner activation using CONSULT only.
Diagnosis sensor unit	If any of the SRS components have been activated: REPLACE the diagnosis sensor unit. Install with new fasteners.
Steering wheel	<ol style="list-style-type: none"> 1. Visually check steering wheel for deformities. 2. Check harness (built into steering wheel) and connectors for damage, and terminals for deformities. 3. Install driver air bag module into the steering wheel to check fit and alignment with the wheel. 4. Check steering wheel for excessive free play. 5. If no damage is found, reinstall. 6. If damaged — REPLACE.
Spiral cable	If the driver front air bag has deployed: REPLACE the spiral cable.

COLLISION DIAGNOSIS

< BASIC INSPECTION >

Part	Inspection
Occupant classification system (Passenger seat)	<ol style="list-style-type: none"> 1. Remove passenger seat assembly. 2. Check control unit case for dents, cracks or deformities. 3. Check connectors for damage and terminals for deformities. 4. Check seat frame and cushion pan for dents or deformities. 5. If no damage is found, reinstall seat with new fasteners. 6. If damaged — REPLACE seat cushion assembly with new fasteners. 7. Perform zero point reset function after front passenger seat is installed in the vehicle and all bolts are tightened to specification. Refer to SRC-39, "ZERO POINT RESET : Special Repair Requirement".
Harness and connectors	<ol style="list-style-type: none"> 1. Check connectors for poor connection, damage, and terminals for deformities. 2. Check harness for binding, chafing, cuts, or deformities. 3. If no damage is found, reinstall the harness and connectors. 4. If damaged — REPLACE the damaged harness. Do not attempt to repair, splice or modify any SRS harness.
Instrument panel assembly	If the passenger front air bag has deployed: REPLACE the instrument panel assembly. (integrated type)

FOR FRONTAL COLLISION: When SRS is not activated in a collision

CAUTION:

Due to varying models and option levels, not all parts listed in the chart below apply to all vehicles.

WORK PROCEDURE

1. Before performing any of the following steps, ensure that all vehicle body and structural repairs have been completed.
2. Check the SRS components using the table below:
Replace any SRS components showing visible signs of damage. (dents, cracks and deformation, etc.)
3. Perform self-diagnosis using CONSULT or air bag warning lamp. Refer to [SRC-14, "Description"](#) for details.
Ensure entire SRS operates properly.
4. After the work is completed, perform self-diagnosis to check that no malfunction is detected. Refer to [SRC-14, "Description"](#).

SRS INSPECTION (FOR FRONTAL COLLISION)

Part	Inspection
Driver air bag module	<p>If the driver air bag has NOT been activated:</p> <ol style="list-style-type: none"> 1. Remove driver air bag module. Check harness cover and connectors for damage, terminals for deformities, and harness for binding. 2. Install driver air bag module into the steering wheel to check fit and alignment with the wheel. 3. If no damage is found, reinstall with new fasteners. 4. If damaged — REPLACE. Install driver air bag modules with new fasteners.
Front passenger air bag module (if equipped)	<p>If the front passenger air bag has NOT been activated:</p> <ol style="list-style-type: none"> 1. Remove front passenger air bag module. Check harness cover and connectors for damage, terminals for deformities, and harness for binding. 2. Install front passenger air bag module into the instrument panel to check fit with the instrument panel. 3. If no damage is found, reinstall with new fasteners. 4. If damaged — REPLACE. Install front passenger air bag modules with new fasteners.
Crash zone sensor	<p>If the front air bags or seat belt pre-tensioners have NOT been activated:</p> <ol style="list-style-type: none"> 1. Remove the crash zone sensor. Check harness connectors for damage, terminals for deformities, and harness for binding. 2. Check for visible signs of damage (dents, cracks, deformation) of the crash zone sensor and bracket. 3. Install the crash zone sensor to check fit. 4. If no damage is found, reinstall with new fasteners. 5. If damaged — REPLACE the crash zone sensor and bracket with new fasteners.

COLLISION DIAGNOSIS

< BASIC INSPECTION >

Part	Inspection	
Seat belt pre-tensioner assemblies (All applicable locations: buckle, retractor, lap outer)	If the pre-tensioners have NOT been activated: <ol style="list-style-type: none"> 1. Remove seat belt pre-tensioners. Check harness cover and connectors for damage, terminals for deformities, and harness for binding. 2. Check belts for damage and anchors for loose mounting. 3. Check retractor for smooth operation. 4. Check seat belt adjuster for damage. 5. Check for deformities of the center pillar inner. 6. If no damage is found, reinstall seat belt pre-tensioner assembly with new fasteners. 7. If damaged —REPLACE. Install the seat belt pre-tensioner assembly with new fasteners. 	A B C
Diagnosis sensor unit	If none of the SRS components have been activated: <ol style="list-style-type: none"> 1. Check case for dents, cracks or deformities. 2. Check connectors for damage, and terminals for deformities. 3. If no damage is found, reinstall with new fasteners. 4. If damaged — REPLACE. Install diagnosis sensor unit with new fasteners. 	D E
Steering wheel	<ol style="list-style-type: none"> 1. Visually check steering wheel for deformities. 2. Check harness (built into steering wheel) and connectors for damage, and terminals for deformities. 3. Install driver air bag module into the steering wheel to check fit and alignment with the wheel. 4. Check steering wheel for excessive free play. 5. If no damage is found, reinstall. 6. If damaged — REPLACE. 	F G
Spiral cable	If the driver front air bag has not deployed: <ol style="list-style-type: none"> 1. Visually check spiral cable and combination switch for damage. 2. Check connectors and protective tape for damage. 3. Check steering wheel for noise, binding or heavy operation. 4. If no damage is found, reinstall. 5. If damaged — REPLACE. 	SR
Occupant classification system (Passenger seat)	<ol style="list-style-type: none"> 1. Remove passenger seat assembly. 2. Check control unit case for dents, cracks or deformities. 3. Check connectors for damage and terminals for deformities. 4. Check seat frame and cushion pan for dents or deformities. 5. If no damage is found, reinstall seat with new fasteners. 6. If damaged — REPLACE seat cushion assembly with new fasteners. 7. Perform zero point reset function after front passenger seat is installed in the vehicle and all bolts are tightened to specification. Refer to SRC-39, "ZERO POINT RESET : Special Repair Requirement". 	I J K
Harness and connectors	<ol style="list-style-type: none"> 1. Check connectors for poor connection, damage, and terminals for deformities. 2. Check harness for binding, chafing, cuts, or deformities. 3. If no damage is found, reinstall the harness and connectors. 4. If damaged —REPLACE the damaged harness. Do not attempt to repair, splice or modify any SRS harness. 	L
Instrument panel assembly	If the passenger front air bag has NOT deployed: <ol style="list-style-type: none"> 1. Visually check instrument panel for damage. 2. If no damage is found, reinstall the instrument panel assembly. 3. If damaged—REPLACE the instrument panel assembly. 	M N

For Side and Rollover Collision

INFOID:000000012430565

FOR SIDE AND ROLLOVER COLLISION: When SRS is activated in a collision

CAUTION:

Due to varying models and option levels, not all parts listed in the chart below apply to all vehicles.

WORK PROCEDURE

1. Before performing any of the following steps, ensure that all vehicle body and structural repairs have been completed.
2. Replace the following components:
 - Front seat back assembly (on the side on which side air bag is activated).
 - Door finisher (on the side on which door-mounted curtain air bag is activated).
 - Pop-up roll bar assemblies and pop-up roll bar covers.
 - Side air bag (satellite) sensor LH/RH (on the side on which side air bag is activated).

COLLISION DIAGNOSIS

< BASIC INSPECTION >

- Diagnosis sensor unit.
- Seat belt pre-tensioner assemblies.
- 3. Check the SRS components and the related parts using the following table.
Replace any SRS components and the related parts showing visible signs of damage (dents, cracks, deformation, etc.).
- 4. Perform self-diagnosis using CONSULT and "AIR BAG" warning lamp. Refer to [SRC-14. "Description"](#) for details. Make sure entire SRS operates properly.
- 5. After the work is completed, perform self-diagnosis to check that no malfunction is detected. Refer to [SRC-14. "Description"](#).

SRS INSPECTION (FOR SIDE AND ROLLOVER COLLISION)

Part	Inspection
Side curtain air bag module LH	If the side curtain air bag LH has deployed: REPLACE the side curtain air bag module LH. Install with new fasteners.
Side curtain air bag module RH	If the side curtain air bag RH has deployed: REPLACE the side curtain air bag module RH. Install with new fasteners.
Front side air bag module LH	If the front side air bag LH has deployed: REPLACE front seatback assembly LH.
Front side air bag module RH	If the front side air bag RH has deployed: REPLACE front seatback assembly RH.
Side air bag (satellite) sensor (LH or RH)	If any of the SRS components have deployed: REPLACE the side air bag (satellite) sensor on the collision side with new fasteners.
Door (satellite) sensor (LH or RH)	If any of the SRS components have deployed: REPLACE the door (satellite) sensor on the collision side with new fasteners.
Diagnosis sensor unit	If any of the SRS components have deployed: REPLACE the diagnosis sensor unit with new fasteners.
Seat belt pre-tensioner assemblies (All applicable locations: buckle, retractor, lap outer)	If either the driver or passenger seat belt pre-tensioner* has been activated: REPLACE all seat belt pre-tensioner assemblies with new fasteners. *: Confirm seat belt pre-tensioner activation using CONSULT only.
Center inner pillar	1. Check the center inner pillar on the collision side for damage (dents, cracks, deformation). 2. If damaged —REPAIR the center inner pillar.
Seat (if equipped with front side air bag)	If either the front LH or front RH side air bag modules has been deployed: REPLACE front seatback assembly on the deployed side.
Trim/headlining	1. Check for visible signs of damage (dents, cracks, deformation) of the interior trim on the collision side. 2. If damaged — REPLACE the damaged trim parts.
Door-mounted curtain air bag module LH	If the door-mounted curtain air bag module LH has been deployed: REPLACE the door finisher LH and door-mounted curtain air bag module. Install with new fasteners.
Door-mounted curtain air bag module RH	If the door-mounted curtain air bag module RH has been deployed: REPLACE the door finisher RH and door-mounted curtain air bag module. Install with new fasteners.
Occupant classification system (Passenger seat)	1. Remove passenger seat assembly. 2. Check control unit case for dents, cracks or deformities. 3. Check connectors for damage and terminals for deformities. 4. Check seat frame and cushion pan for dents or deformities. 5. If no damage is found, reinstall seat with new fasteners. 6. If damaged — REPLACE seat cushion assembly with new fasteners. 7. Perform zero point reset function after front passenger seat is installed in the vehicle and all bolts are tightened to specification. Refer to SRC-39. "ZERO POINT RESET : Special Repair Requirement" .
Pop-up roll bar assemblies	If the pop-up roll bar has deployed: REPLACE pop-up roll bar assemblies and pop-up roll bar covers. Install with new fasteners.

COLLISION DIAGNOSIS

< BASIC INSPECTION >

FOR SIDE AND ROLLOVER COLLISION: When SRS is not activated in a collision

CAUTION:

Due to varying models and option levels, not all parts listed in the chart below apply to all vehicles.

WORK PROCEDURE

1. Before performing any of the following steps, ensure that all vehicle body and structural repairs have been completed.
2. Check the SRS components and the related parts using the following table.
 - If the front seat back assembly is damaged, the front seat back assembly must be replaced.
 - If the door finisher assembly is damaged, the door finisher assembly and door-mounted curtain air bag module must be replaced.
3. Perform self-diagnosis using CONSULT and "AIR BAG" warning lamp. Refer to [SRC-14. "Description"](#) for details. Make sure entire SRS operates properly.
4. After the work is completed, perform self-diagnosis to check that no malfunction is detected. Refer to [SRC-14. "Description"](#).

SRS INSPECTION (FOR SIDE AND ROLLOVER COLLISION)

Part	Inspection
Side curtain air bag module LH	If the side curtain air bag LH has NOT deployed: <ol style="list-style-type: none"> 1. Check for visible signs of damage (dents, tears, deformation) of the center pillar on the collision side. 2. If damaged - Remove the side curtain air bag module LH. 3. Check for visible signs of damage (tears etc.) of the side curtain air bag module LH. 4. Check harness and connectors for damage, and terminals for deformities. 5. If no damage is found, reinstall the side curtain air bag module LH with new fasteners. 6. If damaged — REPLACE the side curtain air bag module LH with new fasteners.
Side curtain air bag module RH	If the side curtain air bag RH has NOT deployed: <ol style="list-style-type: none"> 1. Check for visible signs of damage (dents, tears, deformation) of the center pillar on the collision side. 2. If damaged - Remove the side curtain air bag module RH. 3. Check for visible signs of damage (tears etc.) of the side curtain air bag module RH. 4. Check harness and connectors for damage, and terminals for deformities. 5. If no damage is found, reinstall the side curtain air bag module RH with new fasteners. 6. If damaged — REPLACE the side curtain air bag module RH with new fasteners.
Front side air bag module LH	If the front LH side air bag has NOT deployed: <ol style="list-style-type: none"> 1. Check for visible signs of damage (dents, tears, deformation) of the seat back on the collision side. 2. Check harness and connectors for damage, and terminals for deformities. 3. If damaged — REPLACE the front seatback assembly LH.
Front side air bag module RH	If the front side air bag RH has NOT deployed: <ol style="list-style-type: none"> 1. Check for visible signs of damage (dents, tears, deformation) of the seat back on the collision side. 2. Check harness and connectors for damage, and terminals for deformities. 3. If damaged — REPLACE the front seatback assembly RH.
Side air bag (satellite) sensor (LH or RH)	If none of the SRS components have been activated: <ol style="list-style-type: none"> 1. Remove the side air bag (satellite) sensor (LH or RH) on the collision side. Check harness connectors for damage, terminals for deformities, and harness for binding. 2. Check for visible signs of damage (dents, cracks, deformation) of the side air bag (satellite) sensor (LH or RH). 3. Install the side air bag (satellite) sensor (LH or RH) to check fit. 4. If no damage is found, reinstall the side air bag (satellite) sensor (LH or RH) with new fasteners. 5. If damaged — REPLACE the side air bag (satellite) sensor (LH or RH) with new fasteners.
Door (satellite) sensor (LH or RH)	If none of the SRS components have been activated: <ol style="list-style-type: none"> 1. Remove the door (satellite) sensor (LH or RH) on the collision side. Check harness connectors for damage, terminals for deformities, and harness for binding. 2. Check for visible signs of damage (dents, cracks, deformation) of the door (satellite) sensor (LH or RH). 3. Install the door (satellite) sensor (LH or RH) to check fit. 4. If no damage is found, reinstall the door (satellite) sensor (LH or RH) with new fasteners. 5. If damaged — REPLACE the door (satellite) sensor (LH or RH) with new fasteners.

COLLISION DIAGNOSIS

< BASIC INSPECTION >

Part	Inspection
Diagnosis sensor unit	<p>If none of the SRS components have been activated:</p> <ol style="list-style-type: none"> 1. Check case and bracket for dents, cracks or deformities. 2. Check connectors for damage, and terminals for deformities. 3. If no damage is found, reinstall the diagnosis sensor unit with new fasteners. 4. If damaged — REPLACE the diagnosis sensor unit with new fasteners.
Seat belt pre-tensioner assemblies (All applicable locations: buckle, retractor, lap outer)	<p>If the pre-tensioners have NOT been activated:</p> <ol style="list-style-type: none"> 1. Remove seat belt pre-tensioners. Check harness cover and connectors for damage, terminals for deformities, and harness for binding. 2. Check belts for damage and anchors for loose mounting. 3. Check retractor for smooth operation. 4. Check seat belt adjuster for damage. 5. Check for deformities of the center pillar inner. 6. If no damage is found, reinstall seat belt pre-tensioner assembly with new fasteners. 7. If damaged —REPLACE. Install the seat belt pre-tensioner assembly with new fasteners.
Seat (with front side air bag)	<p>If the front LH or front RH side air bag modules have NOT deployed:</p> <ol style="list-style-type: none"> 1. Visually check the seat on the collision side. 2. Remove the seat on the collision side and check the following for damage and deformities. <ul style="list-style-type: none"> - Harness, connectors and terminals - Frame and recliner (for front and rear seat), and also adjuster and slides (for front seat) 3. If no damage is found, reinstall the seat. 4. If damaged— REPLACE the damaged seat parts using new fasteners. If the front seat back is damaged, the front seat back assembly must be replaced.
Center inner pillar	<ol style="list-style-type: none"> 1. Check the center inner pillar on the collision side for damage (dents, cracks, deformation, etc.). 2. If damaged - REPAIR the center inner pillar.
Trim/headlining	<ol style="list-style-type: none"> 1. Check for visible signs of damage (dents, cracks, deformation, etc.) of the interior trim on the collision side. 2. If damaged - REPLACE the damaged trim parts.
Door-mounted curtain air bag module LH	<p>If the door-mounted curtain air bag LH has NOT deployed:</p> <ol style="list-style-type: none"> 1. Check for visible signs of damage (dents, tears, deformation, etc.) of the door finisher on the collision side. 2. If damaged - REPLACE the door finisher LH with new fasteners. 3. Check for visible signs of damage (tears etc.) of the door-mounted curtain air bag module LH. 4. Check harness and connectors for damage, and terminals for deformities. 5. If no damage is found, reinstall door finisher. <p>CAUTION: When removing door mounted curtain air bag module from door finisher, do not reuse door finisher.</p> <ol style="list-style-type: none"> 6. If damaged - REPLACE the door finisher LH and door-mounted curtain air bag module LH with new fasteners.
Door-mounted curtain air bag module RH	<p>If the door-mounted curtain air bag RH has NOT deployed:</p> <ol style="list-style-type: none"> 1. Check for visible signs of damage (dents, tears, deformation, etc.) of the door finisher on the collision side. 2. If damaged - REPLACE the door finisher RH with new fasteners. 3. Check for visible signs of damage (tears etc.) of the door-mounted curtain air bag module RH. 4. Check harness and connectors for damage, and terminals for deformities. 5. If no damage is found, reinstall door finisher. <p>CAUTION: When removing door mounted curtain air bag module from door finisher, do not reuse door finisher.</p> <ol style="list-style-type: none"> 6. If damaged - REPLACE the door finisher RH and door-mounted curtain air bag module RH with new fasteners.

COLLISION DIAGNOSIS

< BASIC INSPECTION >

Part	Inspection	
Occupant classification system (Passenger seat)	1. Remove passenger seat assembly.	A
	2. Check control unit case for dents, cracks or deformities.	
	3. Check connectors for damage and terminals for deformities.	
	4. Check seat frame and cushion pan for dents or deformities.	B
	5. If no damage is found, reinstall seat with new fasteners.	
	6. If damaged — REPLACE seat cushion assembly with new fasteners.	
	7. Perform zero point reset function after front passenger seat is installed in the vehicle and all bolts are tightened to specification. Refer to SRC-39. "ZERO POINT RESET : Special Repair Requirement" .	C
Pop-up roll bar	If the pop-up roll bar NOT deployed:	
	1. Check for visible signs of damage (dents, tears, deformation, etc.) of the pop-up roll bar.	D
	2. If damaged - REPLACE the pop-up roll bar with new fasteners.	
	3. Check harness and connectors for damage, and terminals for deformities.	
	4. If no damage is found, reinstall the pop-up roll bar with new fasteners.	
	5. Check for visible signs of damage (dents, cracks, deformation, etc.) of the seatback support brace assembly.	E
6. If damaged - REPAIR the seatback support brace assembly.		
		F
		G
		SR
		I
		J
		K
		L
		M
		N
		O
		P

DRIVER AIR BAG MODULE

< REMOVAL AND INSTALLATION >

REMOVAL AND INSTALLATION

DRIVER AIR BAG MODULE

Exploded View

INFOID:000000012542556

TYPE 1

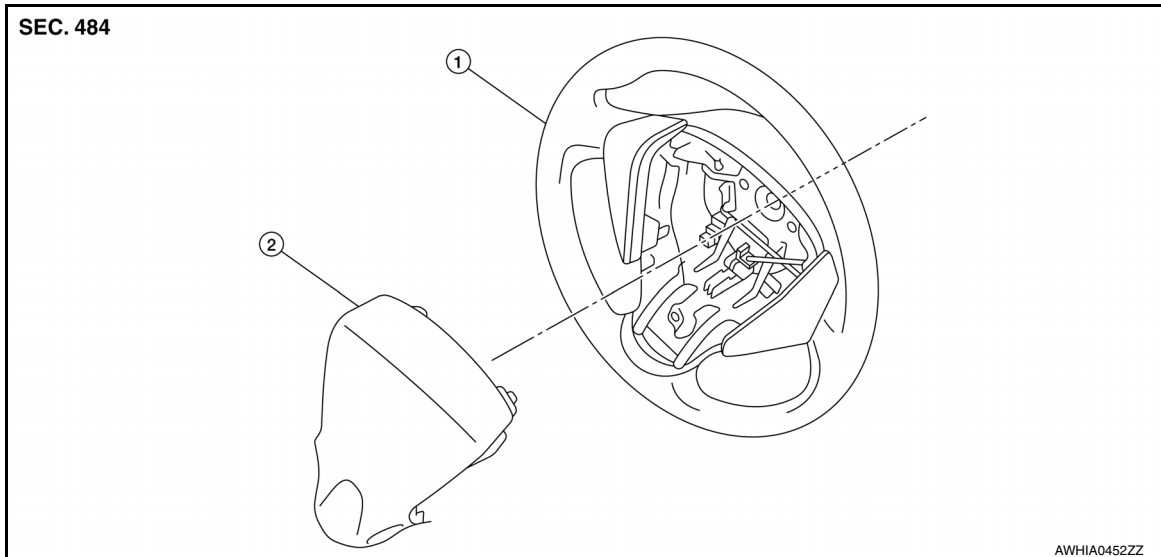

1. Steering wheel

2. Driver air bag module

TYPE 2

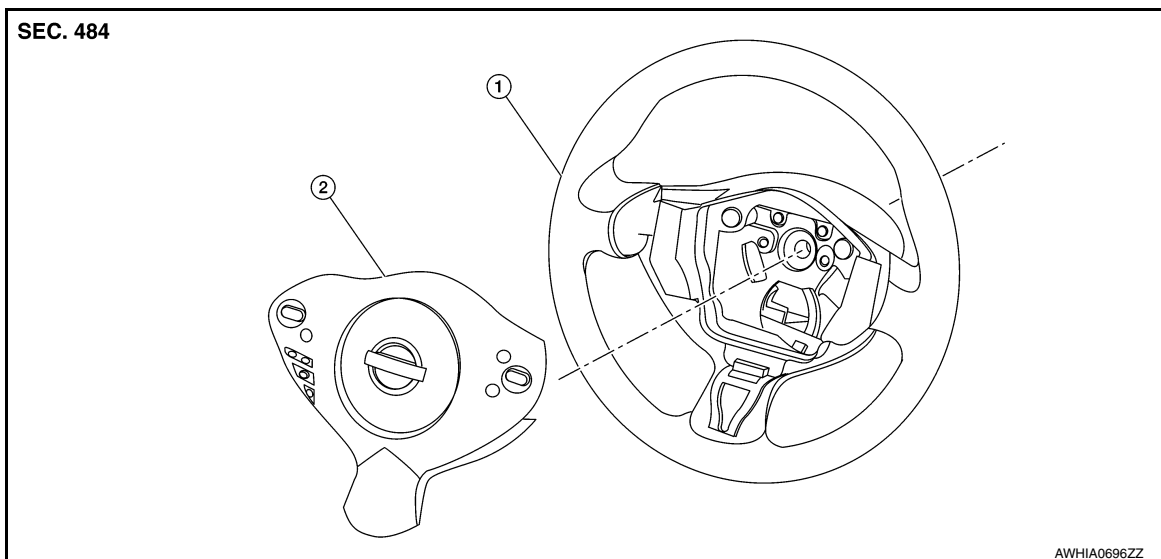

1. Steering wheel

2. Driver air bag module

Removal and Installation

INFOID:000000012542557

WARNING:

- Before servicing the SRS, turn ignition switch OFF, disconnect both battery terminals then wait at least three minutes.
- Always work from the side of driver air bag module. Do not work in front of it.
- If driver air bag module is being replaced due to deployment, the spiral cable must also be replaced. Refer to [SR-16, "Removal and Installation"](#).
- Do not insert any foreign objects (screwdriver, etc.) into the driver air bag module.
- Do not attempt to disassemble the driver air bag module.
- Do not expose the driver air bag module to temperatures exceeding 90°C (194°F).

DRIVER AIR BAG MODULE

< REMOVAL AND INSTALLATION >

- Do not use air tools or electric tools for servicing.

CAUTION:

- Do not allow oil, grease, detergent or water to come in contact with the driver air bag module.

REMOVAL

1. Disconnect negative and positive battery terminals, then wait at least three minutes. Refer to [PG-70, "Removal and Installation \(Battery\)"](#).

2. Remove driver air bag module type 1:

- a. Locate the access holes on side of steering wheel rear finisher (1) and insert (←) a 5.0 mm (0.20 in) diameter suitable tool (A).
- b. Push suitable tool inward (←) and make sure the tool contacts the spring (D). While pushing on spring (D), push on the driver air bag module. The driver air bag module hook will release, then pull to release from steering wheel. Repeat procedure on springs (B) and (C).

NOTE:

Driver air bag module removed for clarity.

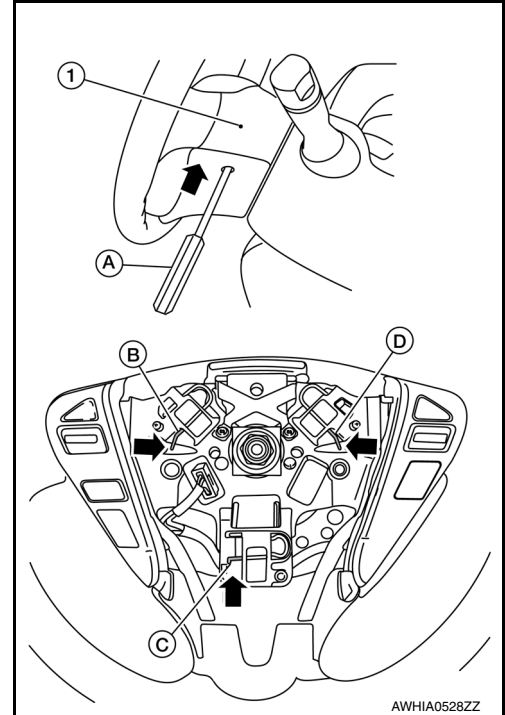

- c. Lift driver air bag module away from the steering wheel and disconnect the driver air bag module harness connectors (A) and the horn harness connector (B). Then remove the harnesses from hook (C).

NOTE:

Take note of harness routing for correct installation.

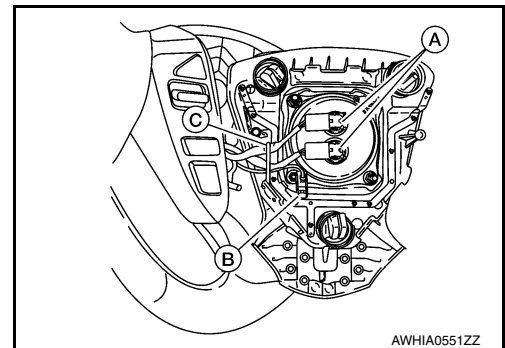

CAUTION:

- For removing/installing the driver air bag module harness connector, insert a thin screwdriver wrapped in tape into the notch, then lift the lock and remove the harness connector as shown.
- Install the harness connector with the lock raised, and push the lock into the connector as shown.
- After installing the connector, check that the lock is pushed in securely.

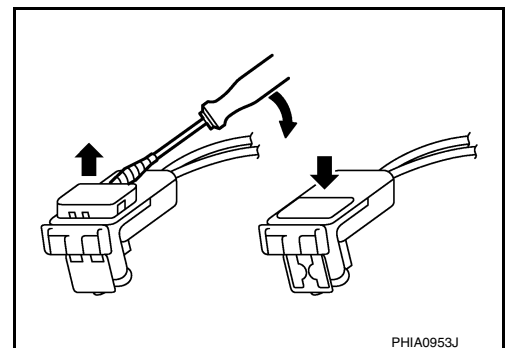

3. Remove driver air bag module type 2:

DRIVER AIR BAG MODULE

< REMOVAL AND INSTALLATION >

- a. Remove side lid (LH and RH).
Insert flat-bladed screwdriver between side lid and steering wheel to disengage pawls as shown in the figure.

 : Pawl

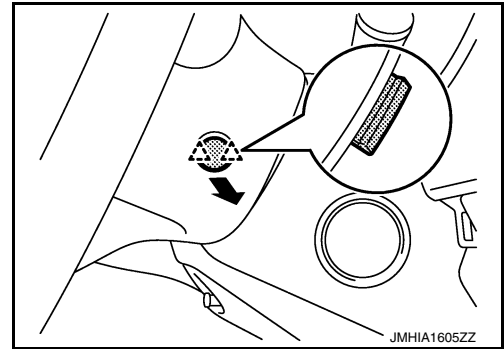

- b. Remove bolts (LH and RH) from the steering wheel lower side.
- c. Pull out driver air bag module.
- d. Disconnect spiral cable harness connector (A).
- e. Disconnect driver air bag harness connector (B).

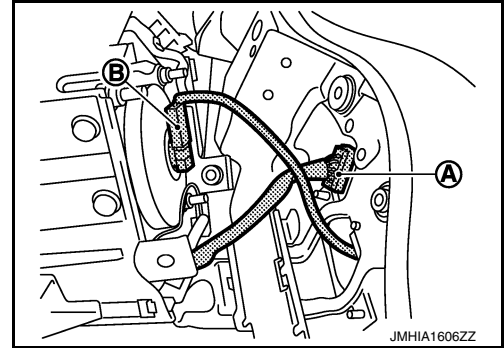

CAUTION:

- For installing/removing the driver air bag module harness connector, insert thin screwdriver wrapped in tape into notch, lift lock and remove the connector.
- Install the connector with lock raised, and push lock into the connector.
- After installing the connector, check that the lock is pushed securely into it.

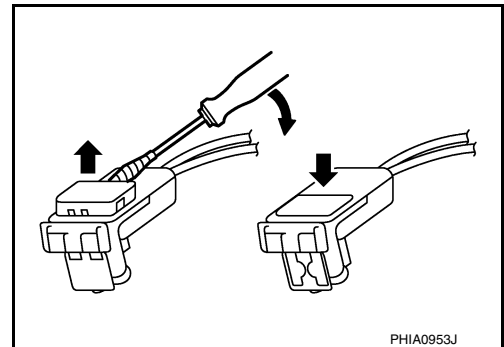

4. Remove the driver air bag module.

NOTE:

Driver air bag type 1 shown, type 2 similar.

CAUTION:

- Always place the driver air bag module with pad side facing upward.

 : Upward

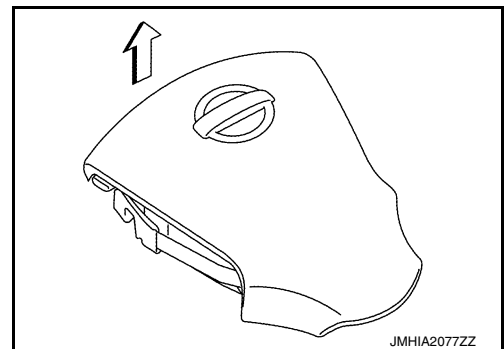

DRIVER AIR BAG MODULE

< REMOVAL AND INSTALLATION >

- Replace the driver air bag module if it has been dropped or sustained an impact.
- Do not strike the driver air bag module.

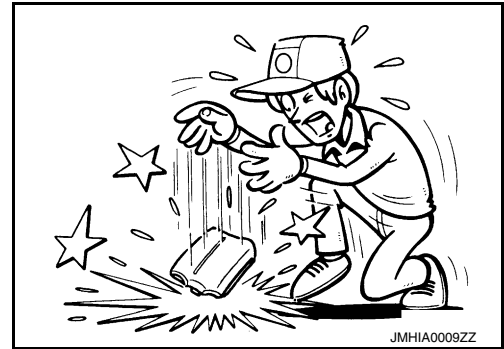

INSTALLATION

Note the following items and install in the reverse order of removal.

CAUTION:

- To install the driver air bag module (type 1) onto the steering wheel, align the hooks over the springs and push to snap into place.
- Fix the driver air bag module (type 2) harnesses to the harness fixing hook (A).

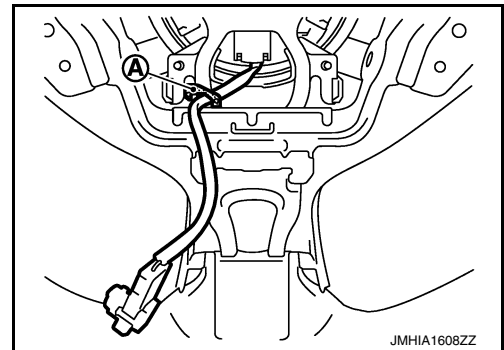

- Be careful not to damage or pinch the harness while installing.
- After the work is completed, check the function of the horn and each steering switch.
- After the work is completed, perform diagnosis to check that no malfunction is detected. Refer to [SRC-14, "Description"](#).

A
B
C
D
E
F
G
SR
I
J
K
L
M
N
O
P

SPIRAL CABLE

< REMOVAL AND INSTALLATION >

SPIRAL CABLE

Exploded View

INFOID:000000012430568

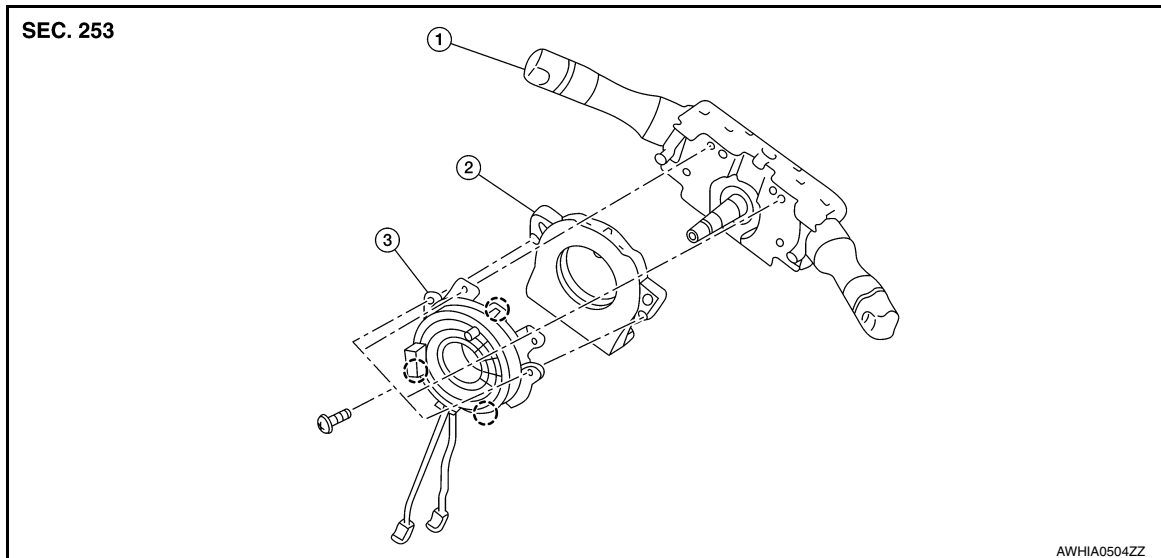

1. Combination switch 2. Steering angle sensor 3. Spiral cable
- Pawl

Removal and Installation

INFOID:000000012430569

WARNING:

- Before servicing the SRS, turn ignition switch OFF, disconnect both battery terminals then wait at least three minutes.
- Do not disassemble the spiral cable.
- Do not use air tools or electric tools for servicing.

CAUTION:

- Do not allow oil, grease, detergent or water to come in contact with the spiral cable.

REMOVAL

1. Disconnect negative and positive battery terminals, then wait at least three minutes. Refer to [PG-70, "Removal and Installation \(Battery\)"](#).
2. Remove steering wheel. Refer to [ST-8, "Removal and Installation"](#).
3. Remove steering column covers. Refer to [IP-17, "Removal and Installation"](#).
4. Disconnect the harness connector (A) from spiral cable and harness connector (B) from steering angle sensor.

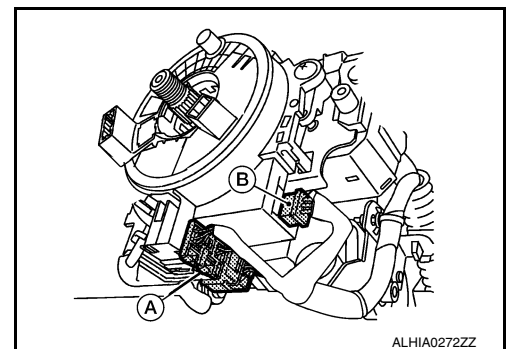

SPIRAL CABLE

< REMOVAL AND INSTALLATION >

5. Remove screws (A), then release pawls and remove spiral cable and steering angle sensor (1) as an assembly.

○: Pawl

CAUTION:

Do not turn the spiral cable quickly or beyond the limit number of turns (approximately 2.5 turns from the neutral position), this may cause the cable to snap.

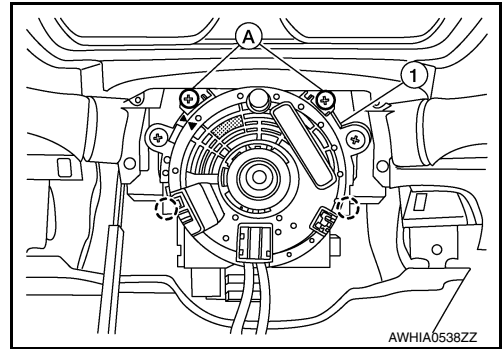

6. Remove screws (A), then release pawls (B) and separate the steering angle sensor (2) from spiral cable (1).

CAUTION:

Do not reuse steering angle sensor.

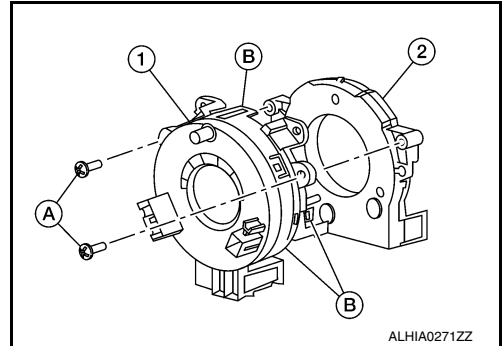

CAUTION:

- Do not strike or drop the spiral cable.
- Replace the spiral cable if it has been dropped or sustained an impact.



INSTALLATION

Installation is in the reverse order of removal.

- The turn signal lever must be in the neutral position for spiral cable installation.

A
B
C
D
E
F
G
SR
I
J
K
L
M
N
O
P

SPIRAL CABLE

< REMOVAL AND INSTALLATION >

- Set the spiral cable neutral position by carefully turning the spiral cable (1) clockwise to the stop position. Turn the spiral cable counterclockwise 2.5 turns stopping when the locating pin (A) is at the top most position, triangles (B) are aligned as shown and the window (C) appears white.

NOTE:

If a new service part is installed, the neutral position is already set with a stopper clip in place and should not be adjusted after the stopper clip is removed. Make sure the stopper clip is removed before installing the steering wheel.

- During steering wheel (2) installation, make sure the locating pin hole (D) is aligned with the locating pin (A) of the spiral cable.
- Adjust the neutral position of the steering angle sensor. Refer to [BRC-55, "ADJUSTMENT OF STEERING ANGLE SENSOR NEUTRAL POSITION : Description"](#).

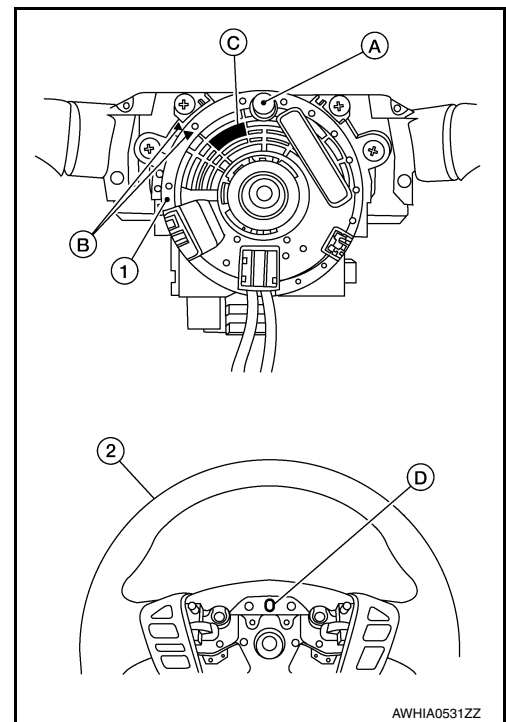

CAUTION:

- The spiral cable may snap during steering operation if the spiral cable is installed in an improper position.
- Do not overturn the spiral cable or go beyond the maximum number of turns allowed. This will cause the cable to snap.
- Do not apply lubricant to the spiral cable.
- Do not allow oil, grease, detergent or water to come in contact with the spiral cable.
- After the work is completed, perform diagnosis to check that no malfunction is detected. Refer to [SRC-14, "Description"](#).

FRONT PASSENGER AIR BAG MODULE

< REMOVAL AND INSTALLATION >

FRONT PASSENGER AIR BAG MODULE

Exploded View

INFOID:000000012430570

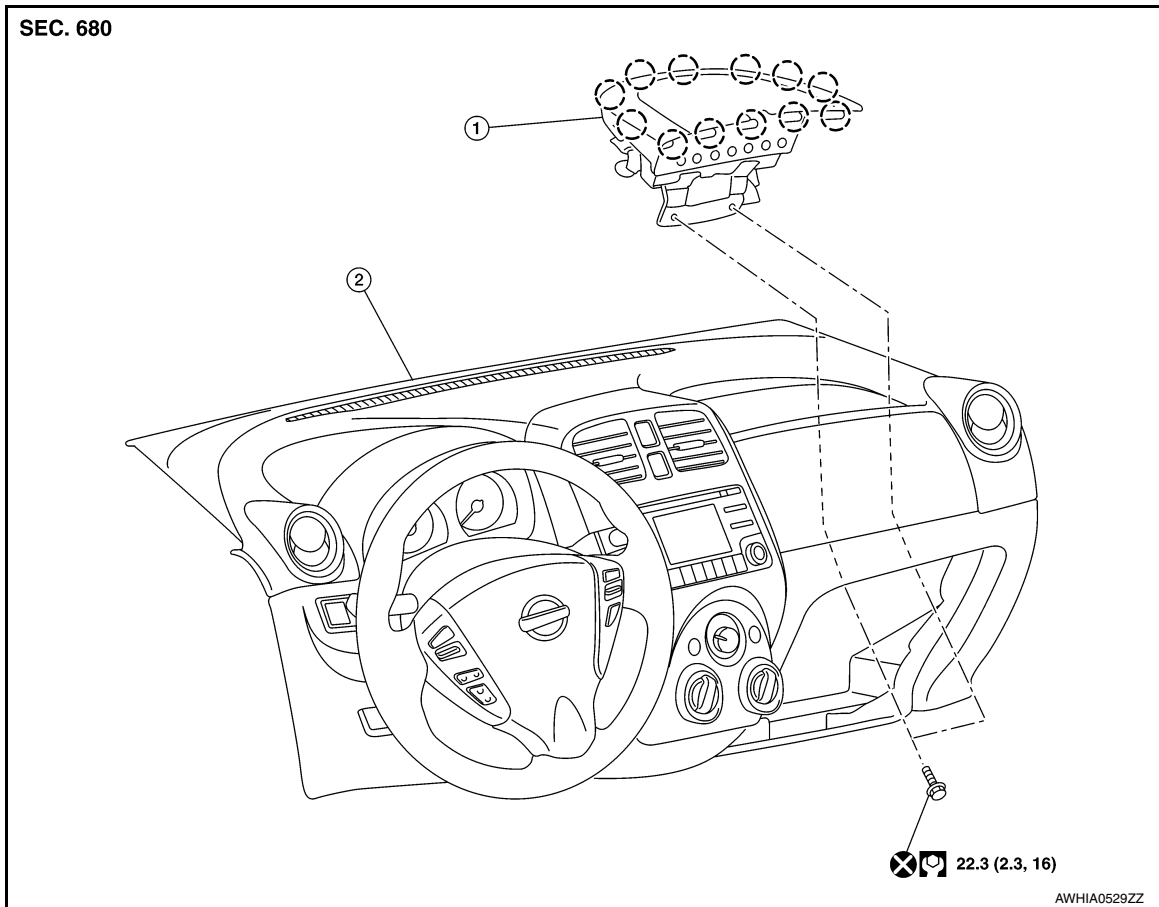

1. Front passenger air bag module

2. Instrument panel assembly

3. Pawl

Removal and Installation

INFOID:000000012430571

WARNING:

- Before servicing the SRS, turn ignition switch OFF, disconnect both battery terminals then wait at least three minutes.
- Always work from the side of air bag module. Do not work in front of it.
- Do not expose the front passenger air bag module to temperatures exceeding 90°C (194°F).
- Do not attempt to disassemble the front passenger air bag module.
- Do not insert any foreign objects (screwdriver, etc.) into the front passenger air bag module.
- Do not use air tools or electric tools for servicing.

CAUTION:

- Do not allow oil, grease, detergent, or water to come in contact with the front passenger air bag module.

REMOVAL

1. Disconnect negative and positive battery terminals, then wait at least three minutes. Refer to [PG-70, "Removal and Installation \(Battery\)"](#).
2. Remove the glove box assembly. Refer to [IP-25, "Removal and Installation"](#).

FRONT PASSENGER AIR BAG MODULE

< REMOVAL AND INSTALLATION >

3. Disconnect the harness connector (A) from front passenger air bag module.
4. Remove and discard the front passenger air bag module bolts (B).

CAUTION:

Do not reuse front passenger air bag module bolts.

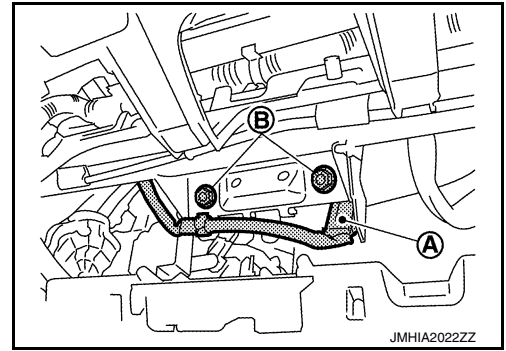

5. Release pawls using a suitable tool and remove front passenger air bag module (1).

○: Pawl

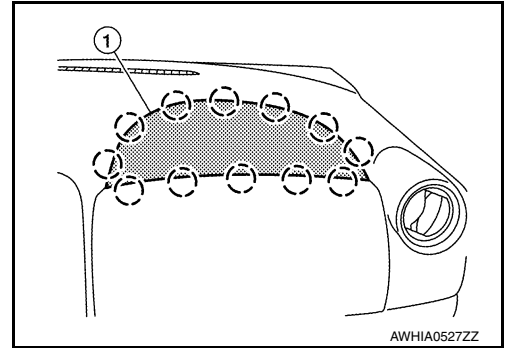

CAUTION:

- Always place the front passenger air bag module with pad side facing upward.

⇧: Upward

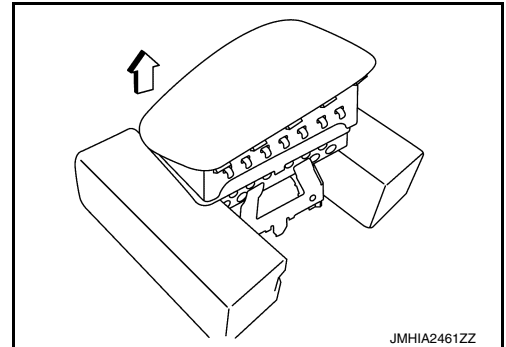

- Do not strike the front passenger air bag module.
- Replace the front passenger air bag module if it has been dropped or sustained an impact.



INSTALLATION

Installation is in the reverse order of removal.

CAUTION:

- Do not reuse the front passenger air bag module bolts.
- Do not damage the front passenger air bag module harness during installation.
- After the work is completed, perform diagnosis to check that no malfunction is detected. Refer to [SRC-14, "Description"](#).

SIDE CURTAIN AIR BAG MODULE

< REMOVAL AND INSTALLATION >

SIDE CURTAIN AIR BAG MODULE

Exploded View

INFOID:000000012430572

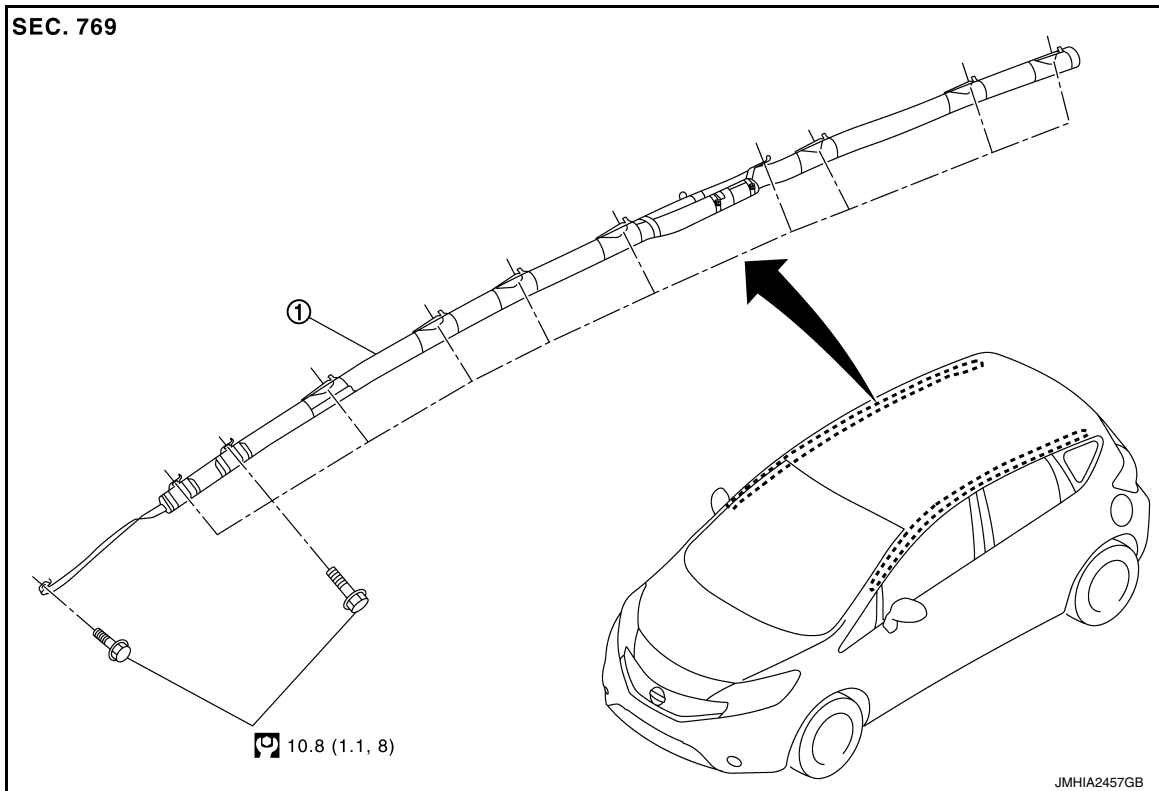

1. Side curtain air bag module

Removal and Installation

INFOID:000000012430573

WARNING:

- Before servicing the SRS, turn ignition switch OFF, disconnect both battery terminals then wait at least three minutes.
- Always work from the side of air bag module. Do not work in front of it.
- Replace the side curtain air bag module if it has been dropped or sustained an impact.
- Do not attempt to disassemble the side curtain air bag module.
- Do not strike the side curtain air bag module.
- Do not insert any objects (screwdriver, etc.) into the side curtain air bag module.
- Do not expose the side curtain air bag module to temperatures exceeding 93°C (200°F).
- Do not use air tools or electric tools for servicing.

CAUTION:

- Do not allow oil, grease, detergent or water to come in contact with the side curtain air bag module.

REMOVAL

1. Disconnect negative and positive battery terminals, then wait at least three minutes. Refer to [PG-70. "Removal and Installation \(Battery\)"](#).
2. Remove the headlining. Refer to [INT-31. "Removal and Installation"](#).
3. Disconnect the harness connector from the side curtain air bag module.

CAUTION:

A
B
C
D
E
F
G
SR
I
J
K
L
M
N
O
P

SIDE CURTAIN AIR BAG MODULE

< REMOVAL AND INSTALLATION >

- For removing/installing the side curtain air bag module harness connector, insert a thin screwdriver wrapped in tape into the notch, lift the lock and remove the harness connector as shown.
- Install the harness connector with the lock raised, and push the lock into the harness connector as shown.
- After installing the harness connector, check that the lock is pushed in securely.

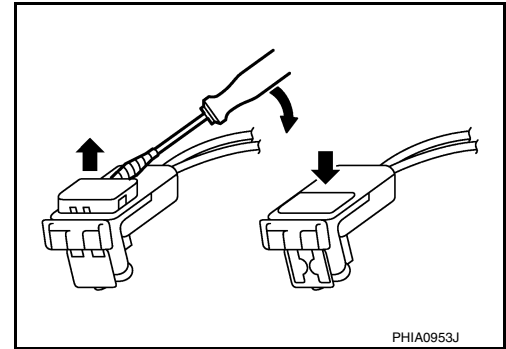

4. Remove the tether bolt, then the remaining side curtain air bag module bolts.

INSTALLATION

Installation is in the reverse order of removal.

WARNING:

When installing the side curtain air bag module make sure it is not twisted between attachment brackets.

CAUTION:

- Make sure to attach the double stick tape to the tether and adhere it to the pillar.
- Do not damage the harness while installing the side curtain air bag module.
- After the work is completed, perform self-diagnosis to check that no malfunction is detected. Refer to [SRC-14, "Description"](#).

SIDE AIR BAG MODULE

< REMOVAL AND INSTALLATION >

SIDE AIR BAG MODULE

Removal and Installation

INFOID:000000012430574

The side air bag module is part of the front seatback. Refer to [SE-20. "DRIVER SIDE : Removal and Installation"](#) (DRIVER SIDE) or [SE-22. "PASSENGER SIDE : Removal and Installation"](#) (PASSENGER SIDE).

A
B
C
D
E
F
G
SR
I
J
K
L
M
N
O
P

CRASH ZONE SENSOR

< REMOVAL AND INSTALLATION >

CRASH ZONE SENSOR

Exploded View

INFOID:000000012430575

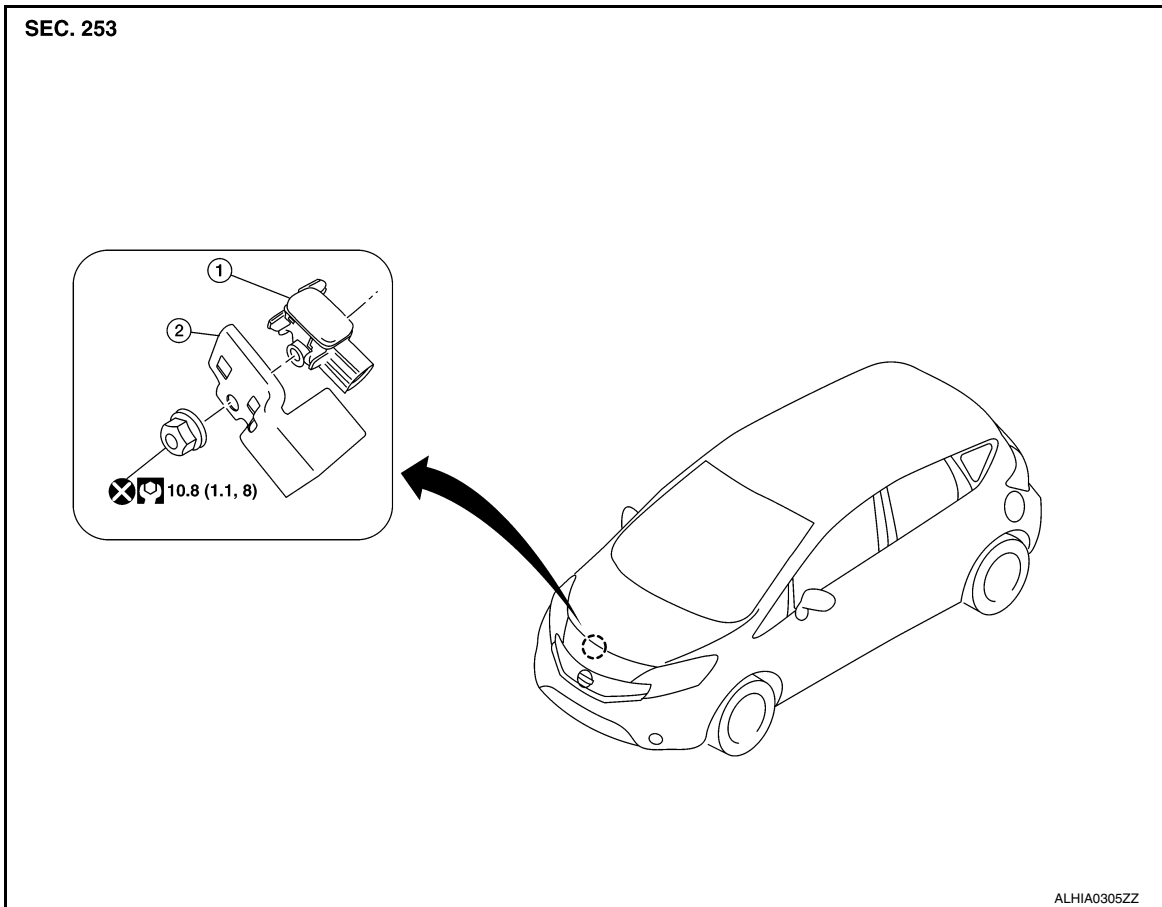

1. Crash zone sensor

2. Bracket

Removal and Installation

INFOID:000000012430576

WARNING:

- Before servicing the SRS, turn ignition switch OFF, disconnect both battery terminals then wait at least three minutes.
- Replace the crash zone sensor if it has been dropped or sustained an impact.
- Replace the crash zone sensor if either the driver air bag module, the front passenger air bag module, or a front seat belt pre-tensioner has been deployed.
- Do not strike the crash zone sensor.
- Do not use air tools or electric tools for servicing.

REMOVAL

1. Disconnect negative and positive battery terminals, then wait at least three minutes. Refer to [PG-70](#), "[Removal and Installation \(Battery\)](#)".

CRASH ZONE SENSOR

< REMOVAL AND INSTALLATION >

2. Remove and discard crash zone sensor nut (A).

CAUTION:

Do not reuse crash zone sensor nut.

3. Remove bracket (1) and crash zone sensor (2).

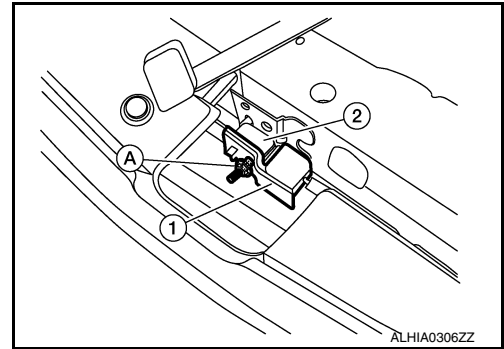

4. Disconnect the slide double locking type harness connector from the crash zone sensor, as shown.

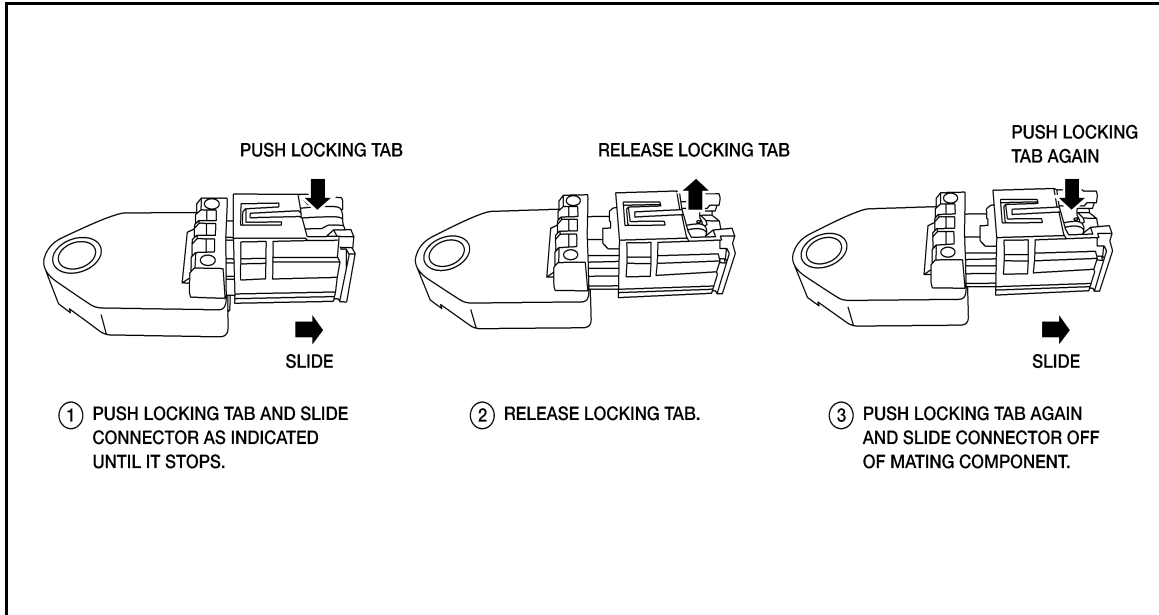

INSTALLATION

Installation is in the reverse order of removal.

Position the crash zone sensor using the locating pin before tightening the nut to specification.

CAUTION:

- Do not reuse the crash zone sensor nut.
- Do not damage the harness connector during installation.
- After the work is completed, perform diagnosis to check that no malfunction is detected. Refer to [SRC-14, "Description"](#).

A
B
C
D
E
F
G
SR
I
J
K
L
M
N
O
P

SATELLITE SENSOR

< REMOVAL AND INSTALLATION >

SATELLITE SENSOR

Exploded View

INFOID:000000012430577

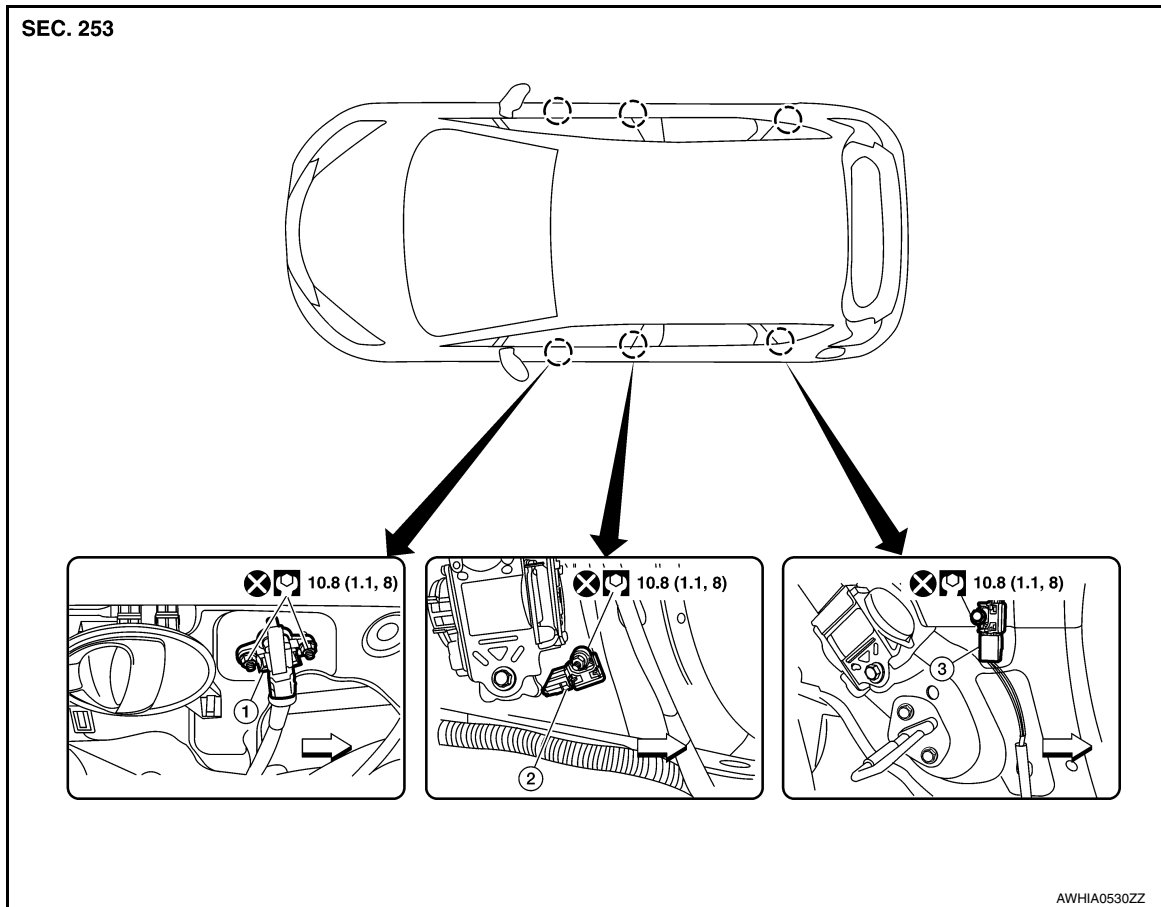

1. Front door satellite sensor 2. Front side air bag satellite sensor 3. Rear side air bag satellite sensor

← Front

Removal and Installation - Front Door Satellite Sensor

INFOID:000000012430578

WARNING:

- Before servicing the SRS, turn ignition switch OFF, disconnect both battery terminals then wait at least three minutes.
- Replace the front door satellite sensor if it has been dropped or sustained an impact.
- Do not use air tools or electric tools for servicing.
- Replace the front door satellite sensor (LH/RH) if either the side air bag module or the side curtain air bag module has been deployed.
- Do not strike the front door satellite sensor.

REMOVAL

1. Disconnect negative and positive battery terminals, then wait at least three minutes. Refer to [PG-70, "Removal and Installation \(Battery\)"](#).
2. Remove front door finisher. Refer to [INT-15, "Removal and Installation"](#).

SATELLITE SENSOR

< REMOVAL AND INSTALLATION >

3. Disconnect the slide double locking type harness connector from the front door satellite sensor, as shown.

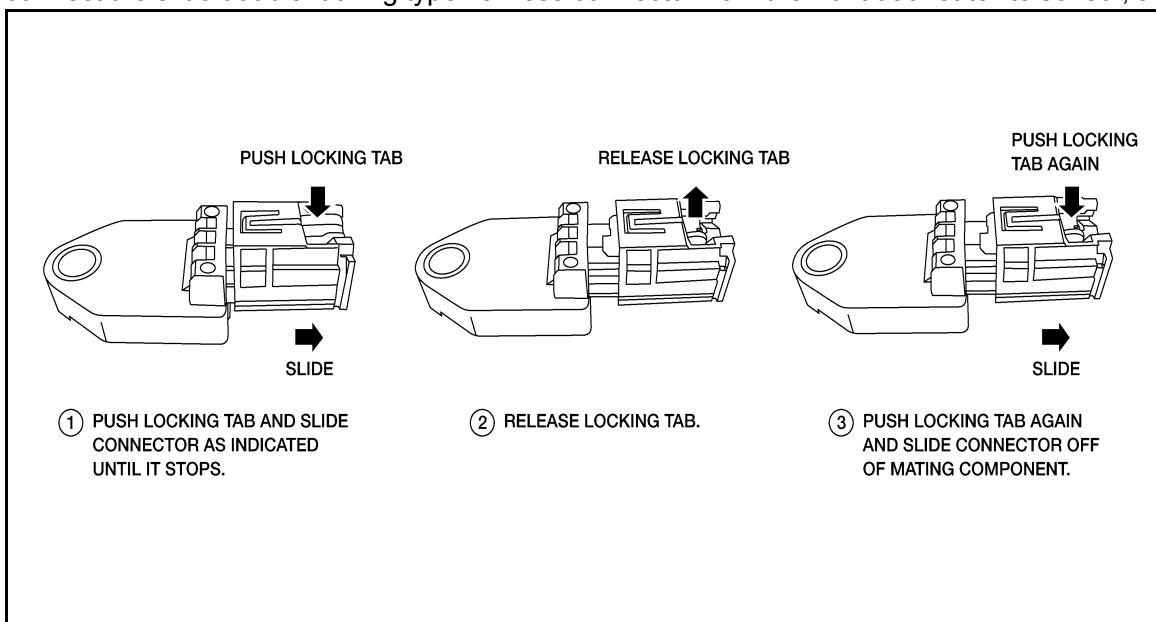

4. Remove and discard front door satellite sensor nuts.

CAUTION:

Do not reuse front door satellite sensor nuts.

5. Remove front door satellite sensor.

INSTALLATION

Installation is in the reverse order of removal.

CAUTION:

- Do not reuse front door satellite sensor nuts.
- Do not damage the harness connector during installation.
- After the work is completed, perform self-diagnosis to check that no malfunction is detected. Refer to [SRC-14, "Description"](#).

Removal and Installation - Front Side Air Bag Satellite Sensor

INFOID:000000012430579

WARNING:

- Before servicing the SRS, turn ignition switch OFF, disconnect both battery terminals then wait at least three minutes.
- Do not strike the front side air bag satellite sensor.
- Replace the front side air bag satellite sensor if it has been dropped or sustained an impact.
- Do not use air tools or electric tools for servicing.
- Replace the front side air bag satellite sensor (LH/RH) if either the side air bag module or the side curtain air bag module has been deployed.

REMOVAL

1. Disconnect negative and positive battery terminals, then wait at least three minutes. Refer to [PG-70, "Removal and Installation \(Battery\)"](#).
2. Remove center pillar lower finisher. Refer to [INT-25, "CENTER PILLAR LOWER FINISHER : Removal and Installation"](#).
3. Remove and discard front side air bag satellite sensor nut.
CAUTION:
Do not reuse front side air bag satellite sensor nut.
4. Remove front side air bag satellite sensor.

SATELLITE SENSOR

< REMOVAL AND INSTALLATION >

5. Disconnect the slide double locking type harness connector from front side air bag satellite sensor, as shown.

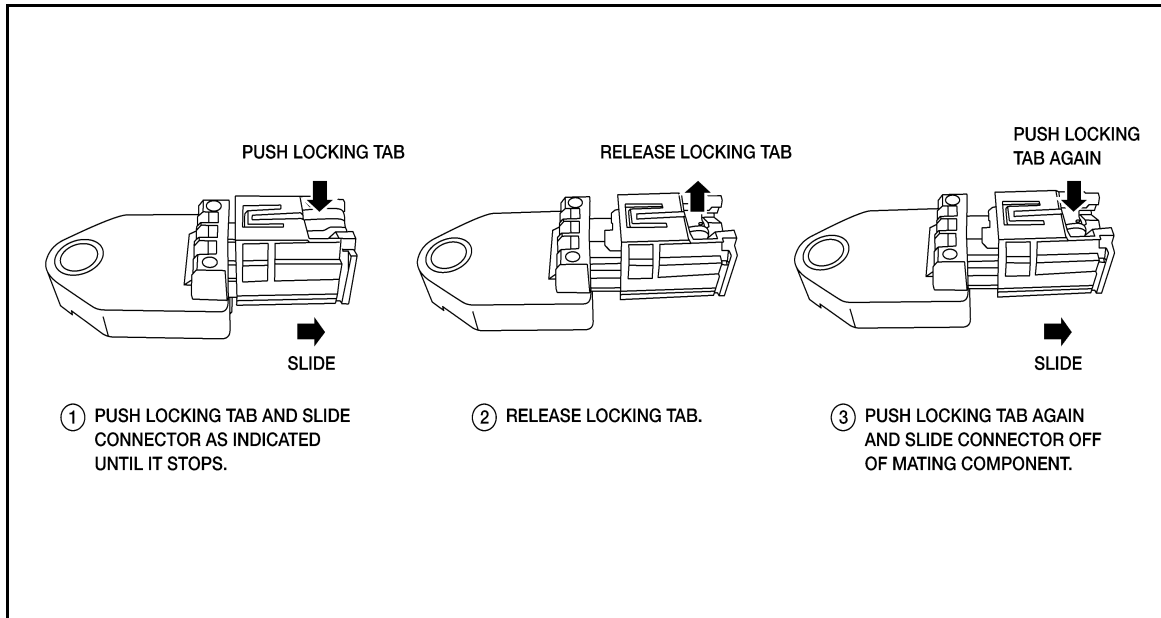

INSTALLATION

Installation is in the reverse order of removal.

Position the front side air bag satellite sensor using the locating pin before tightening the nut to specification.

CAUTION:

- Do not reuse the front side air bag satellite sensor nut.
- Do not damage the harness connector during installation.
- After the work is completed, perform self-diagnosis to check that no malfunction is detected. Refer to [SRC-14, "Description"](#).

Removal and Installation - Rear Side Air Bag Satellite Sensor

INFOID:000000012430580

WARNING:

- Before servicing the SRS, turn ignition switch OFF, disconnect both battery terminals then wait at least three minutes.
- Replace the rear side air bag satellite sensor if it has been dropped or sustained an impact.
- Replace the rear side air bag satellite sensor (LH/RH) if either the side air bag module or the side curtain air bag module has been deployed.
- Do not strike the rear side air bag satellite sensor.
- Do not use air tools or electric tools for servicing.

REMOVAL

1. Disconnect negative and positive battery terminals, then wait at least three minutes. Refer to [PG-70, "Removal and Installation \(Battery\)"](#).
2. Remove luggage side lower finisher. Refer to [INT-34, "LUGGAGE SIDE LOWER FINISHER : Removal and Installation"](#).

SATELLITE SENSOR

< REMOVAL AND INSTALLATION >

3. Disconnect the slide double locking type harness connector from rear side air bag satellite sensor, as shown.

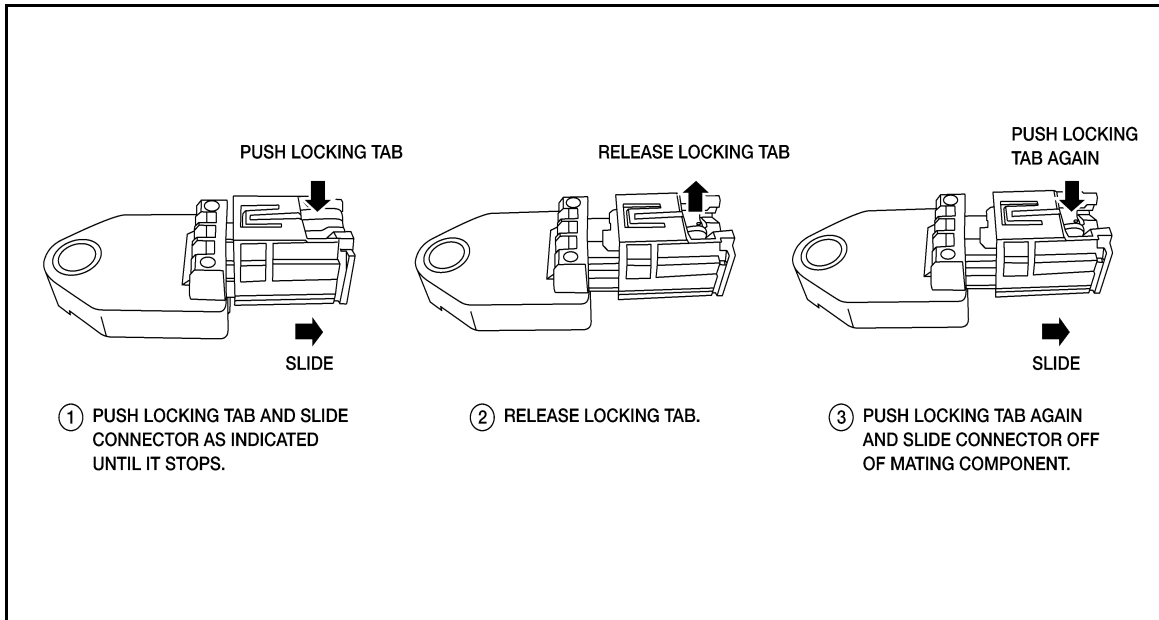

4. Remove and discard rear side air bag satellite sensor bolt.

CAUTION:

Do not reuse rear side air bag satellite sensor bolt.

5. Remove rear side air bag satellite sensor.

INSTALLATION

Installation is in the reverse order of removal.

Position the rear side air bag satellite sensor using the locating pin before tightening the bolt to specification.

CAUTION:

- Do not reuse rear side air bag satellite sensor bolt.
- Do not damage the harness connector during installation.
- After the work is completed, perform self-diagnosis to check that no malfunction is detected. Refer to [SRC-14, "Description"](#).

A
B
C
D
E
F
G
SR
I
J
K
L
M
N
O
P

AIR BAG DIAGNOSIS SENSOR UNIT

< REMOVAL AND INSTALLATION >

AIR BAG DIAGNOSIS SENSOR UNIT

Exploded View

INFOID:000000012430581

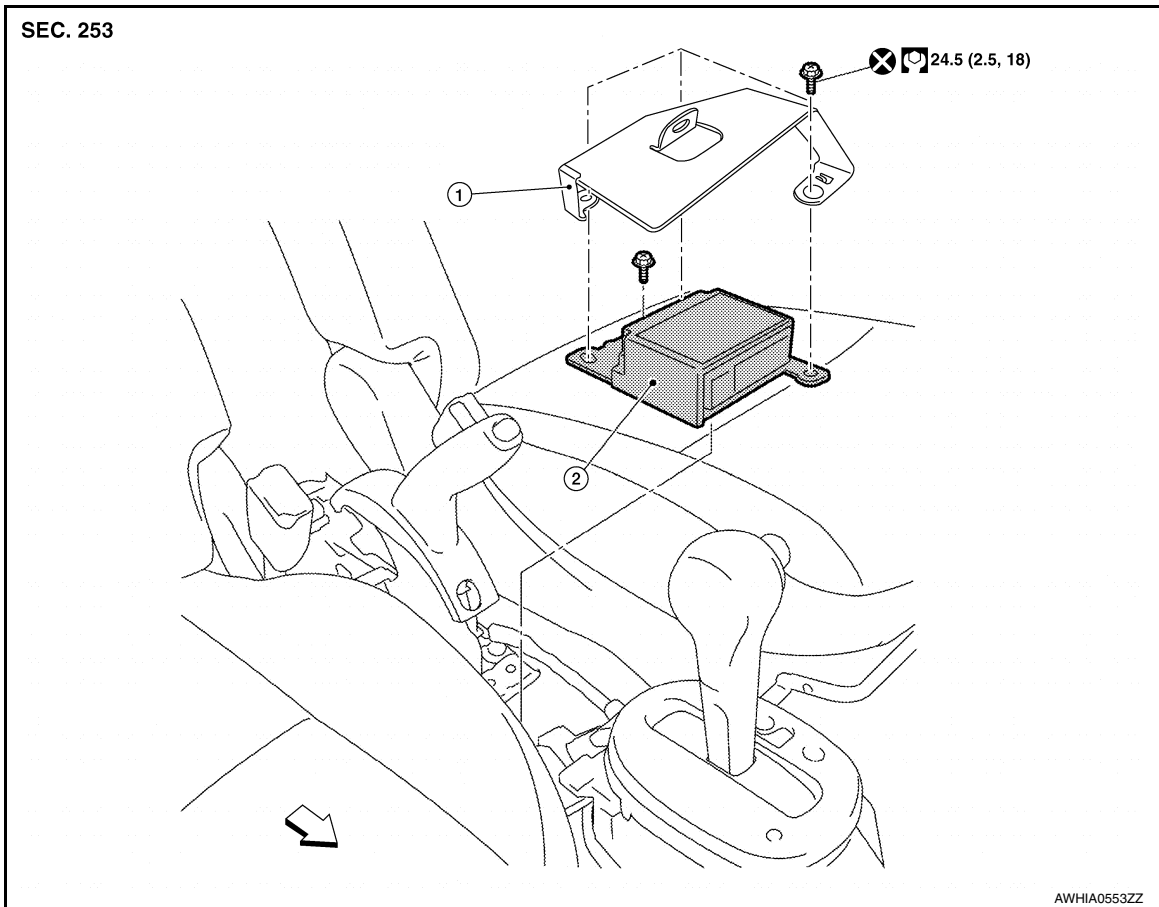

1. Bracket

2. Air bag diagnosis sensor unit

← Front

Removal and Installation

INFOID:000000012430582

REMOVAL

WARNING:

- Before servicing the SRS, turn ignition switch OFF, disconnect both battery terminals then wait at least three minutes.
- Replace the air bag diagnosis sensor unit if any SRS air bag has been deployed or if any front seat belt pre-tensioner has been deployed.
- Before disconnecting the air bag diagnosis sensor unit harness connectors, be sure to disconnect each harness connector of the front seat belt pre-tensioners (LH/RH) to prevent accidental air bag deployment by static electricity and seat belt pre-tensioner operation.
- Do not use the air tools or electric tools for servicing.
- When replacing the air bag diagnosis sensor unit, always check with the parts department for the latest parts information. Installing an incorrect air bag diagnosis sensor unit may or may not cause the air bag warning lamp to illuminate and may cause incorrect deployment of the supplemental air bags and seat belt pre-tensioners in a collision resulting in serious personal injury or death.

1. Always check the air bag diagnosis sensor unit ECU discriminated number (identification number) or part number using CONSULT.
2. Disconnect negative and positive battery terminals, then wait at least three minutes. Refer to [PG-70, "Removal and Installation \(Battery\)"](#).
3. Remove center pillar lower finisher. Refer to [INT-25, "CENTER PILLAR LOWER FINISHER : Removal and Installation"](#).

AIR BAG DIAGNOSIS SENSOR UNIT

< REMOVAL AND INSTALLATION >

4. Disconnect the harness connectors from the front seat belt pre-tensioners (LH/RH).

CAUTION:

- For removing/installing the front seat belt pre-tensioner harness connector, insert a thin screwdriver wrapped in tape into the notch, then lift the lock and remove the harness connector as shown.
- Install the harness connector with the lock raised, and push the lock into the harness connector as shown.
- After installing the harness connector, check that the lock is pushed in securely.

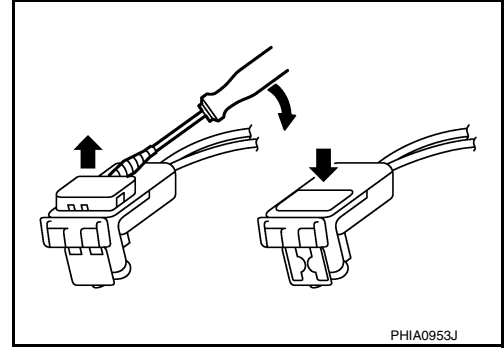

5. Remove the center console assembly. Refer to [IP-18, "Removal and Installation"](#).

6. Disconnect the harness connectors (A) from the air bag diagnosis sensor unit.

7. Remove and discard bolts (B), then remove bracket and air bag diagnosis sensor unit.

CAUTION:

Do not reuse air bag diagnosis sensor unit bolts.

NOTE:

Shown with bracket removed for clarity.

↔: Front

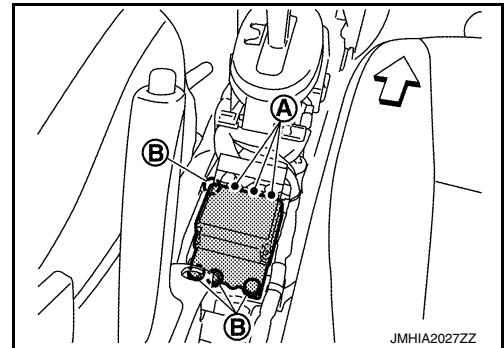

CAUTION:

- Do not strike the air bag diagnosis sensor unit.
- Replace the air bag diagnosis sensor unit if it has been dropped or sustained an impact.

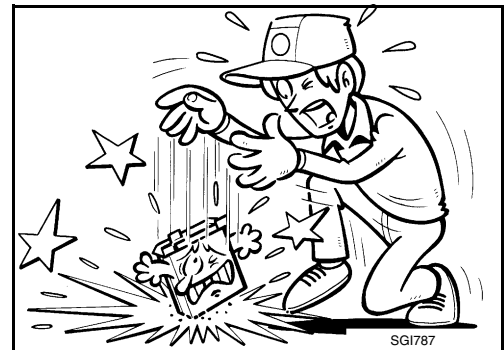

INSTALLATION

Installation is in the reverse order of removal.

CAUTION:

- Do not reuse the air bag diagnosis sensor unit bolts.
- The air bag diagnosis sensor unit must always be installed with the label arrow mark "↔" pointing toward the front of the vehicle for proper operation.
- Do not damage the air bag diagnosis sensor unit harness or connectors during installation.
- After replacing the air bag diagnosis sensor unit, confirm using CONSULT that the ECU discriminated number (identification number) or part number of the new replacement air bag diagnosis sensor unit matches the ECU discriminated number (identification number) or part number of the replaced (old) air bag diagnosis sensor unit.
- After the work is completed, perform diagnosis to check that no malfunction is detected. Refer to [SRC-14, "Description"](#).

NOTE:

If the ECU discriminated number or part number of the new replacement air bag diagnosis sensor unit differs from the ECU discriminated number or part number of the replaced air bag diagnosis sensor unit, reconfirm the parts information and verify that the correct air bag diagnosis sensor unit was installed.

A
B
C
D
E
F
G
SR

I
J
K
L
M
N
O
P

OCCUPANT CLASSIFICATION SYSTEM CONTROL UNIT

< REMOVAL AND INSTALLATION >

OCCUPANT CLASSIFICATION SYSTEM CONTROL UNIT

Removal and Installation

INFOID:000000012430583

OCCUPANT CLASSIFICATION SYSTEM CONTROL UNIT

WARNING:

- Before servicing the SRS, turn ignition switch OFF, disconnect both battery terminals then wait at least three minutes.
- Do not use air tools or electric tools for servicing.

Removal

1. Slide front passenger seat to full forward position.
2. Disconnect negative and positive battery terminals, then wait at least three minutes. Refer to [PG-70, "Removal and Installation \(Battery\)"](#).
3. Release front J-clips, then disconnect harness connector from occupant classification system control unit.
4. Remove screws and occupant classification system control unit.

CAUTION:

- Replace the occupant classification control unit if it has been dropped or sustained an impact.
- Do not strike the occupant classification control unit.

Installation

Installation is in the reverse order of removal.

WARNING:

- Zero point reset must be performed every time the occupant classification system control unit is removed/replaced. Refer to [SRC-39, "ZERO POINT RESET : Description"](#).

CAUTION:

- Do not damage the harness connector during installation.
- After installation is complete, check that no system malfunction is detected causing the air bag warning lamp to illuminate.
- If a malfunction is indicated by the air bag warning lamp after repair or replacement of the malfunctioning parts, perform the diagnosis. Refer to [SRC-16, "Trouble Diagnosis with CONSULT"](#).

OCCUPANT CLASSIFICATION SYSTEM SENSORS

WARNING:

- Before servicing the SRS, turn ignition switch OFF, disconnect both battery terminals then wait at least three minutes.
- Do not use air tools or electric tools for servicing.

Removal

1. Disconnect negative and positive battery terminals, then wait at least three minutes. Refer to [PG-70, "Removal and Installation \(Battery\)"](#).
2. Remove front passenger seat. Refer to [SE-22, "PASSENGER SIDE : Removal and Installation"](#).
3. Disconnect harness connectors from occupant classification system sensors.
4. Remove nuts (LH/RH) and remove seat frame from seat tracks.
5. Remove nuts from occupant classification sensor and remove.

Installation

1. Install occupant classification system sensor to seat track using nuts.

CAUTION:

- Do not reuse nuts. Replace with new part during installation.
- Tighten nuts to specification.

Occupant classification sensor nuts :22 N·m (2.2 kg-m, 16 ft-lb)

2. Install seat frame to seat track using nuts and washer.

CAUTION:

Do not reuse nuts or washer. Replace with new part during installation.

OCCUPANT CLASSIFICATION SYSTEM CONTROL UNIT

< REMOVAL AND INSTALLATION >

NOTE:

Tighten front nuts by hand first, then tighten front nuts to specification, then tighten rear nuts to specification.

Seat track nuts :45 N·m (4.6 kg-m, 33 ft-lb)

3. Connect harness connectors to occupant classification sensors, then install front passenger seat. Refer to [SE-22. "PASSENGER SIDE : Removal and Installation"](#).

CAUTION:

- Do not damage the harness connector during installation.
- After installation is complete, check that no system malfunction is detected causing the air bag warning lamp to illuminate.
- If a malfunction is indicated by the air bag warning lamp after repair or replacement of the malfunctioning parts, perform the diagnosis. Refer to [SRC-16. "Trouble Diagnosis with CONSULT"](#).

A
B
C
D
E
F
G
I
J
K
L
M
N
O
P

SR

SEAT BELT PRE-TENSIONER

< REMOVAL AND INSTALLATION >

SEAT BELT PRE-TENSIONER

Removal and Installation

INFOID:000000012430584

The front seat belt pre-tensioner is part of the front seat belt retractor. Refer to [SB-9. "SEAT BELT RETRAC-TOR : Removal and Installation"](#).

FRONT SEAT BELT BUCKLE SWITCH

< REMOVAL AND INSTALLATION >

FRONT SEAT BELT BUCKLE SWITCH

Removal and Installation

INFOID:000000012430585

The front seat belt buckle switch is part of the front seat belt buckle. Refer to [SB-8, "FRONT SEAT BELT BUCKLE : Removal and Installation"](#).

A
B
C
D
E
F
G
SR
I
J
K
L
M
N
O
P

FRONT PASSENGER AIR BAG OFF INDICATOR

< REMOVAL AND INSTALLATION >

FRONT PASSENGER AIR BAG OFF INDICATOR

Removal and Installation

INFOID:000000012430586

Removal

1. Remove cluster lid C. Refer to [IP-22. "Removal and Installation"](#).
2. Release pawls and remove front passenger air bag off indicator (1) from cluster lid C (2).

○: Pawl

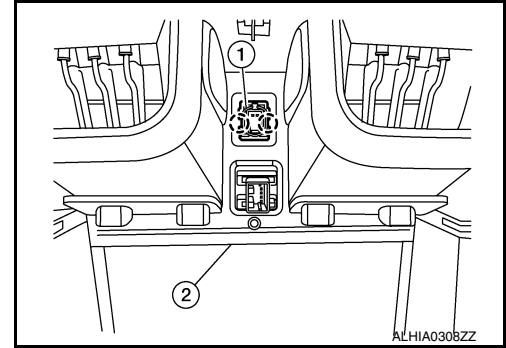

Installation

Installation is in the reverse order of removal.